

ICT SITE INVERTER 300



INSTRUCTION MANUAL

INNOVATIVE CIRCUIT TECHNOLOGY LTD.

SAFETY & WARNINGS

Read this manual carefully and understand all Warnings and Cautions before connections are made to the Inverter. If unsure about any aspects of the installation call ICT Technical Support at (604) 856-6303, 8:00AM to 4:30PM Pacific Standard Time.

- ▶ **WARNING:** Check the battery polarity and voltage before connecting the unit. Incorrect polarity will damage the unit.
- ▶ **WARNING:** Make sure that all the DC connections are tight. Loose connections could result in overheating and can be a potential hazard.
- ▶ **WARNING:** The AC neutral lead is internally bonded to chassis. The chassis must be bonded to earth ground through the external ground connector located at the back of the unit.
- ▶ **WARNING:** Do not attempt to operate the Inverter from any power source other than a battery.
The 12 Volt Inverter (ICT300-12SNV) must be connected to a **12 Volt** battery.
The 24 Volt Inverter (ICT300-24SNV) must be connected to a **24 Volt** battery.
The 48 Volt Inverter (ICT300-48SNV) must be connected to a **48 Volt** battery.
Connecting the Inverter to any other battery may damage to unit.
- ▶ **WARNING:** Calculate the total power consumption (W) of the output load. Make sure the total power consumption does not exceed the rated load capacity of the Inverter.
- ▶ **CAUTION:** No user serviceable parts inside. Only ICT personnel are authorized to service the unit.
- ▶ **CAUTION:** It is the installer's responsibility to ensure compliance with all applicable installation codes and regulations.
- ▶ **CAUTION:** Before any connections are made to the unit or system, be sure to disconnect the battery terminals. Always disconnect the grounded battery terminal first. When reconnecting, connect ungrounded terminal first, and grounded terminal last.
- ▶ **CAUTION:** Avoid mounting the unit near sources of moisture, flammable gases or fumes.
- ▶ **CAUTION:** Do not block the fan opening on the front of the Inverter.
- ▶ **CAUTION:** Follow the provided wire size recommendations provided in this manual. DC connection cables should be as short as possible and large enough to handle the required current in accordance with the electrical codes or regulations applicable to your installation. Cables that are not an adequate gauge, or are too long, will result in excessive voltage drop, decrease inverter performance, and possibly damage the unit.
- ▶ **CAUTION:** To ensure that the Inverter's safety features are not compromised, use the Inverter as specified in the manual and do not substitute parts or make any unauthorized modifications.
- ▶ Install an in-line fuse (not supplied) in the positive lead from the battery to the Inverter (see page 4).

INTRODUCTION

Whether your communications site is off the grid, or designed to operate from DC power for uninterrupted quality of service, certain components still require high quality, reliable AC sine wave power to operate.

The ICT SITE INVERTER 300 is a low profile, high performance sine–wave inverter that converts DC energy from your battery source into 300 watts of utility grade power for site equipment that requires AC electricity, such as radio links, multiplexers, routers, or digital video recorders. ICT inverters provide extremely low harmonic distortion and high efficiency, meaning that your equipment receives extremely quiet, high quality power.

Up to three ICT SITE INVERTER 300's can be mounted in a single 1RU 19 inch rack shelf, to provide almost 1kW of power (non–parallel) and six AC outlets in an ultra–compact, space saving design.

Other options include a wall mount bracket for mounting a single inverter outside the rack, and an accessory kit that provides two AC outlets on the front faceplate of the inverter rack.

FEATURES

The ICT SITE INVERTER 300 is designed specifically for communications site applications, and includes the following features:

- ▶ Two rear–facing AC outlets for easy access to the equipment that needs to be powered.
- ▶ Rear–mounted DC input studs for connection to the DC battery source.
- ▶ A grounding stud on the rear of the unit.
- ▶ Front mounted power switch and LED indicator lights.
- ▶ Thermo–controlled, ball bearing brushless cooling fan blowing front to back ensures the best thermal performance and longevity for the internal components.
- ▶ Air intake is from the front of the unit.
- ▶ LED indicators provide information on AC status and on the built–in protection features, including input voltage condition, overload, and temperature shutdown conditions.
- ▶ Operating temperature range from –20C to +60C.
- ▶ Capable of handling up to twice its rated capacity, or 600 watts, for up to three seconds.
- ▶ No additional clearance is required top or bottom.

OPTIONS

- ▶ 1RU 19" mounting rack (model number ICT–RMK3) holds 1, 2, or 3 inverters.
- ▶ Wall Mount Bracket (ICT–SWB) for single inverter.
- ▶ Front AC Outlet Kit (ICT–ACF) provides two AC power outlets on the front of the ICT–RMK3 rack mount kit (requires one open mounting position and one Site Inverter 300). Includes AC power cord to route AC from the Site Inverter 300 to the front facing outlets.

Figure 1: ICT Inverter Front Panel

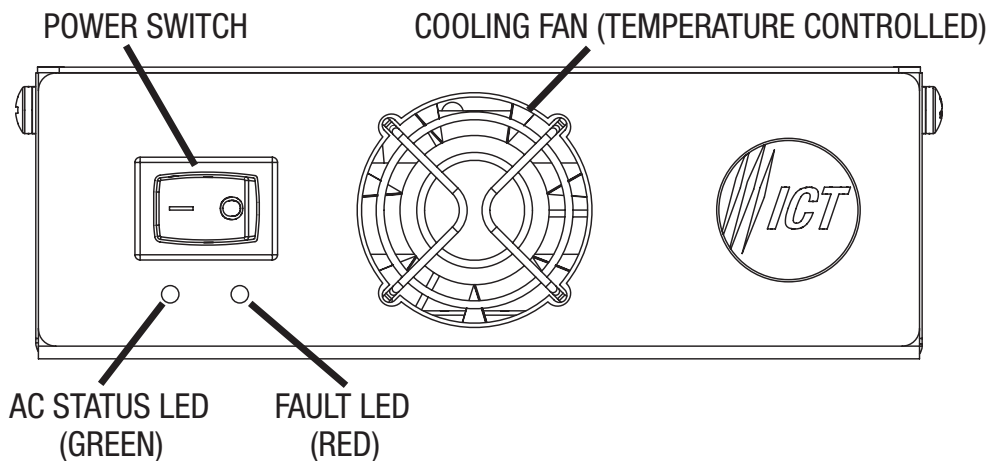
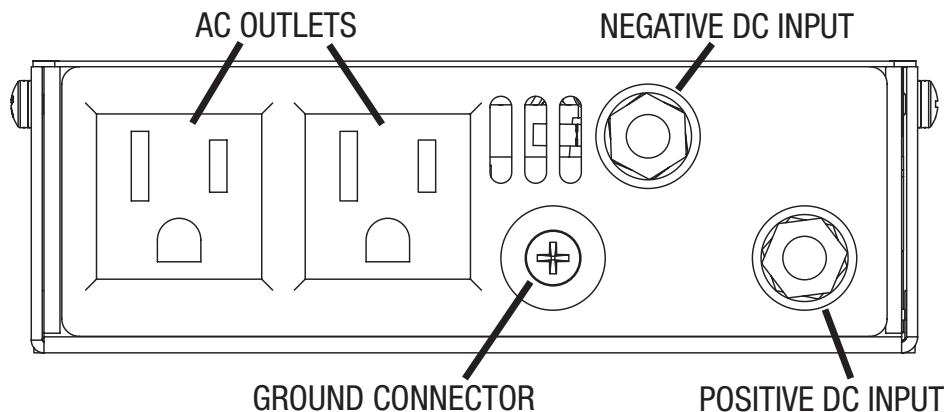

Figure 2: ICT Inverter Back Panel



PROTECTIONS

Overload Protection: The Inverter will shut down if the AC output is shorted, or if the continuous draw exceeds 300 Watts for more than three seconds. The Inverter can be manually reset by turning the Power Switch located on the front panel off, then on. The Inverter can supply up to 600 Watts during the overload event, allowing this inverter to start larger loads.

Under Voltage Protection: The Inverter will shut down if the battery discharges below 10.5 Vdc (21.0 Vdc for 24V Inverter / 42.0 Vdc for 48V Inverter). The Inverter will automatically restart when battery voltage rises to at least 11.8 Vdc (23.6 Vdc for 24V Inverter / 47.2 Vdc for 48V Inverter).

Over Voltage Protection: The Inverter will shut down if the battery voltage exceeds 16.0 Vdc (32.0 Vdc for 24V Inverter / 64.0 Vdc for 48V Inverter). The Inverter will automatically restart when battery voltage drops below 15.0 Vdc (30.0 Vdc for 24V Inverter / 60.0 Vdc for 48V Inverter).

Over Temperature Protection: If the Inverter is subjected to higher ambient temperatures than the maximum rated temperature, or if the cooling vents or fan openings are blocked, the unit will shut down. The Inverter will automatically restart after the unit cools down.

INSTALLATION

1. Ensure the Power Switch located on the front panel is in the OFF position before installing the unit.
2. Mount the unit as close to the battery as possible. Shorter wires between the inverter and battery will result in higher efficiencies (Refer to “**Wire Sizing Guide**” on page 6).
3. For safety, the metal chassis of the inverter must be grounded to earth. Connect the Ground Connector located on the back panel to the earth ground connection using **#10 AWG** copper wire.
4. An in–line fuse is recommended to protect the battery and wiring to the unit. Use a **40 Amp** fuse for 12V Inverter models, a **20 Amp** fuse for 24V Inverter models, or a **10 Amp** fuse for 48V Inverter models. The in–line fuse should be connected to the positive wire within 18 inches of the battery. Connect the battery to the input terminals located on the back panel as shown in Figure 3. See “**Wire Sizing Guide**” on page 6 for recommended input wire sizes.

Ensure the positive terminal of the battery is connected to the Positive Input of the inverter, and the negative terminal of the battery to the Negative Input of the inverter. Incorrect polarity will blow the internal fuse and damage the unit.

Figure 3: ICT Inverter Wiring Diagram

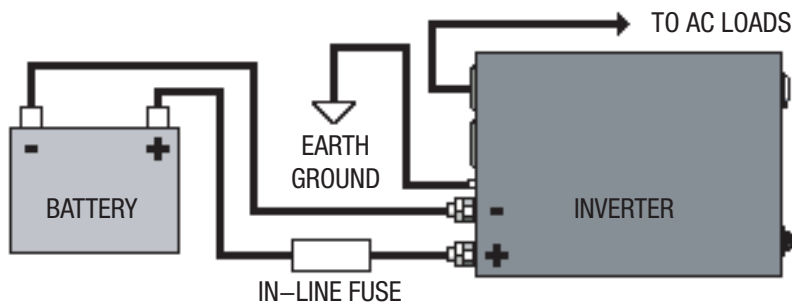

5. Plug your AC loads into the AC Outlets located on the back panel.

Rack Mounting

If installing the ICT Site Inverter 300 into an equipment rack, use the optional 1RU 19 inch rack mounting kit (part number ICT–RMK3). 1, 2 or 3 inverters can be installed in one ICT–RMK3. Position the inverter into the rack tray, and using the two supplied mounting screws, fasten the inverter to the tray by inserting the screws through the tray and into the integrated nuts located on the bottom of the inverter. Do not over tighten.

If mounting a second or third inverter, remove the cover plates from the front faceplate of the rack tray by pushing out the plastic fasteners holding the cover plates from the back, and mount the inverters. Retain the cover plates and plastic fasteners for future use.

Install the rack tray with the inverters into your equipment rack. Wiring connections can be made before or after this step, depending on your specific situation. Remember to follow all guidelines and cautions about connecting the inverters.

Figure 4: Rack Mount Installation

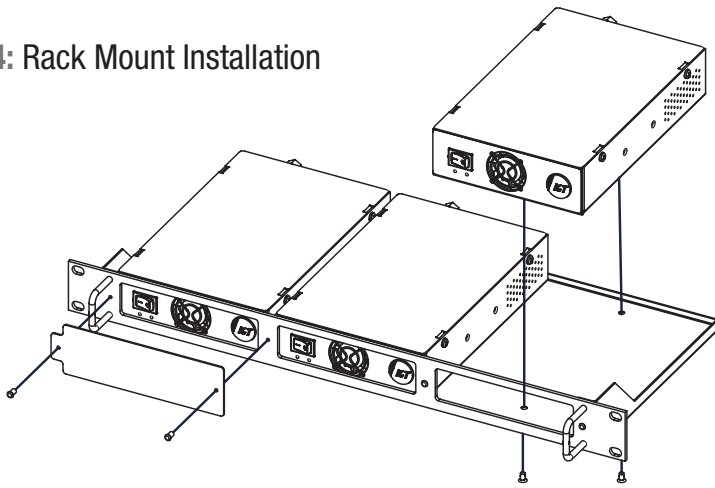

Wall Mounting

If mounting the Inverter on a wall or other solid surface using the optional wall mount bracket (part number ICT-SWB), mount the unit horizontally as shown in Figure 5. The unit can also be mounted flat on a horizontal surface such as a desktop. Any other mounting orientation may compromise the safety of the Inverter.

Figure 5: Wall Mount Installation

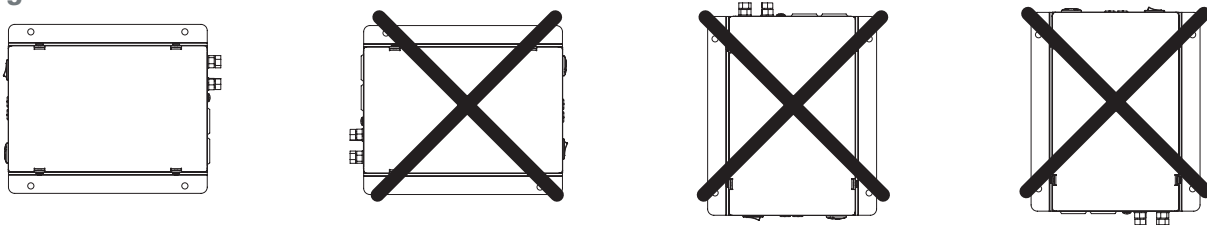

WIRE SIZING GUIDE

Distance of Inverter from Battery:	12V Inverter Recommended Input Wire Size (copper):	24V Inverter Recommended Input Wire Size (copper):	48V Inverter Recommended Input Wire Size (copper):
0 – 5 feet	#10 AWG (34855)	#12 AWG (34855)	#12 AWG (34855)
5 – 10 feet	#6 AWG (52042)	#10 AWG (34855)	#12 AWG (34855)
10 – 20 feet	#4 AWG (52043)	#8 AWG (52041)	#10 AWG (34855)

Note: Use TE Connectivity / Amp part number for Terminal Connector listed in brackets after the wire gauge size (or equivalent).

OPERATION

Turn the Power Switch located on the front panel to the ON position. The Green LED below the Power Switch should turn on to indicate the inverter is operational.

Status of LED Indicator Lights:

AC Status LED	Fault LED	Status
GREEN	OFF	AC Output ON
GREEN	RED (BLINK)	Under Voltage Warning
OFF	RED (BLINK)	Under Voltage Shutdown
OFF	RED	Overload or Inverter Fault

TROUBLESHOOTING

No AC Output Voltage. No Indicator LEDs are illuminated:

- ▶ Check the DC wiring to the unit for loose connections or blown fuses.
- ▶ Ensure that the Power Switch is in the ON position.

No AC Output Voltage. Red Fault LED is blinking:

- ▶ The battery is discharged. The Inverter will automatically restart when the battery voltage rises to at least 11.8 Vdc (23.6 Vdc for 24V Inverter / 47.2 Vdc for 48V Inverter).

No AC Output Voltage. Red Fault LED is on steady:

- ▶ The Inverter may be overloaded. Check that the Input Power requirements of the load do not exceed the rated Output Power of the Inverter. Reset the Inverter by cycling the Power Switch.
- ▶ The battery voltage may be too high. The Inverter will automatically restart when the battery voltage drops below 15.0 Vdc (30.0 Vdc for 24V Inverter / 60.0 Vdc for 48V Inverter).
- ▶ The Inverter may have overheated. The Inverter will automatically restart after it cools down. Ensure that the unit has adequate ventilation if this happens.

PRODUCT SPECIFICATIONS

	ICT300–12SNV	ICT300–24SNV	ICT300–48SNV
Input Voltage:	10.5 – 16.0 Vdc	21.0 – 32.0 Vdc	42.0 – 64.0 Vdc
Output Voltage:	115 Vac +/- 5V		
Output Waveform:	Pure Sine Wave		
Output Frequency:	60 Hz +/- 0.05 Hz		
Total Harmonic Distortion (THD):	< 3% THD		
Continuous Output Power:	300 Watts		
Maximum Surge Power:	600 Watts (for 3 seconds)		
No Load Power Consumption:	4 Watts		
Efficiency (full load):	90%	91%	93%
Peak Efficiency:	> 91%	> 91%	93%
Input Current (maximum):	35 Amps	18 Amps	9 Amps
Under Voltage Warning:	11.0 Vdc +/- 0.25 V	22.0 Vdc +/- 0.5 V	44.0 Vdc +/- 1.0 V
Under Voltage Shutdown:	10.5 Vdc +/- 0.25 V	21.0 Vdc +/- 0.5 V	42.0 Vdc +/- 1.0 V
Under Voltage Recovery:	11.8 Vdc +/- 0.25 V	23.6 Vdc +/- 0.5 V	47.2 Vdc +/- 1.0 V
Over Voltage Shutdown:	16.0 Vdc +/- 0.25 V	32.0 Vdc +/- 0.5 V	64.0 Vdc +/- 1.0 V
Over Voltage Recovery:	15.0 Vdc +/- 0.25 V	30.0 Vdc +/- 0.5 V	60.0 Vdc +/- 1.0 V
Operating Temperature:	–20°C to +60°C		
Size (Length x Width x Height):	9.6" x 5.3" x 1.7"		
Weight:	2.2 lbs		
Cooling:	Forced Air (Temperature Controlled)		
DC Input Connectors:	1/4 Inch Bronze Studs		
AC Output Connectors:	Dual NEMA 5–15R North American Receptacles		
Chassis Grounding Connector:	8–32 Screw With Internal Tooth Lock Washer		

LIMITED WARRANTY

ICT Ltd. warrants to the original consumer purchaser that this product shall be in good working order, free from defects in materials and workmanship, for a period of two (2) years from the date of purchase. Should failure occur during the above stated time period, then ICT will, at its option, repair or replace this product at no additional charge except as set forth below. All parts, whether for repair or replacement, will be furnished on an exchange basis. All exchange pieces become the property of ICT. This limited warranty shall not apply if the ICT product has been damaged by unreasonable use, accident, negligence, disaster, service, or modification by anyone other than the ICT factory.

Limited warranty service is obtained by delivering the product during the above stated two (2) years warranty period to an authorized ICT dealer or ICT factory and providing proof of purchase date. If this product is delivered by mail, you will insure the product or assume risk of loss or damage in transit, and prepay shipping charges to the factory.

Every reasonable effort has been made to ensure that ICT product manuals and promotional materials accurately describe ICT product specifications and capabilities at the time of publication. However, because of ongoing improvements and updating of ICT products, ICT cannot guarantee the accuracy of printed materials after the date of publication and disclaims liability for changes, errors or omissions.

If this ICT product is not in good working order, as outlined in the above warranty, your sole remedy shall be repair or replacement as provided above. In no event will ICT be liable for any damages resulting from the use of or the inability to use the ICT product, even if an ICT employee or an authorized ICT dealer has been advised of the possibility of such damages, or for any claim by any other party.

ICT reserves the right to make changes without further notice to any products or documentation for improvement of reliability, function, or design.

ICT Ltd. does not recommend use of its products in life support applications wherein a failure or malfunction of the product may directly or indirectly threaten life or cause injury. The user of ICT products, which are to be used in life support applications as described above, assumes all risks of such use and indemnifies ICT against all damages.

INNOVATIVE CIRCUIT TECHNOLOGY LTD.
26921 GLOUCESTER WAY LANGLEY, BRITISH COLUMBIA, CANADA V4W 3Y3
T 604.856.6303 F 604.856.6365 www.ict-power.com

